

PFERD

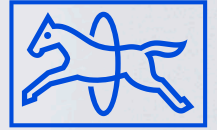

TOOLS



Cut-off wheels for stationary applications

Cut-off wheels for stationary applications

Table of contents



Cut-off wheels for stationary applications

■ Highlights from the PFERD TOOLS range – custom-made products	3
■ Highlights from the PFERD TOOLS range	4
■ General information	4
■ Safety notes	4
■ Transport and storage	6
■ Product lines and color coding	6
■ Quick product selection guide	7
■ Custom-made products	9



CHOPSAW cut-off wheels 12–16" dia.

■ Universal Line PSF ★★☆☆	11
■ Performance Line SG ★★★★★	12



CHOPSAW HD cut-off wheels 12–16" dia.

■ Performance Line SG ★★★★★	14
-----------------------------	----



Rail cut-off wheels dia. 14" – 16"

■ Universal Line PSF ★★☆☆	15
■ Performance Line SG ★★★★★	15



HEAVY DUTY cut-off wheels 10–26" dia.

■ Special Line SGP ★★★★★	16
--------------------------	----



Reducing rings for stationary cut-off wheels

■ Reducing rings for stationary cut-off wheels	18
--	----



Cut-off wheels for stationary applications

Highlights from the PFERD TOOLS range – custom-made products



What is the best way to select a stationary cut-off wheel?

Our experienced technical advisers will start by analyzing your current set-up. They will visit you on site to see your machine, application and the wheel dimensions. PFERD TOOLS will determine the wheel thickness based on how thick the wheel needs to be for cutting. The drive output of the machine motor and the diameter of the clamping flange are also important for selecting the right stationary cut-off wheel. Based on this information and other data, we determine which customized solution PFERD TOOLS can produce for you.



What are the operating conditions and which cross sections need to be cut?

In addition to the information about the machine, it is essential to know the operating conditions for the cutting work. A distinction is made between cold (up to 212°F), warm (212 to 1,112°F) and hot cutting-off (1,112 to over 1,832°F), depending on the material temperature of the workpieces being cut. The main cutting applications are cross sections measuring 1 inch to 20 inches in a round design, and square designs from 2 inches to 10 inches (depending on the specific requirements and industry), as well as a range of profiles such as various rails. Based on the operating conditions and cross sections, you can determine which wheel diameter is required/recommended.



For medium-sized cut-off wheels the range is 400 – 600 mm (16" – 24", traditional applications in foundries, finishing processes and when cutting to size); for large cut-off wheels the range is 800 – 2,000 mm (32" – 80", applications in rolling mills and forging plants in the steel production industry).

What are the cut requirements?

A good result for cold cutting-off is that the cut surface is blank (no blue or brown discoloration) and that the cut itself is perpendicular. The heat ingress into the material should also be minimal to prevent hard spots at the ends of the cut, which could cause cracks in the steel. Ideally, the formation of burrs on the material should be minimized to negate the need for reworking. The blank cut does not play a role in warm and hot cutting-off – the aim here is to ensure a long service life, a perpendicular cut and a reliable process.



Customized solutions

On request, we can produce stationary cut-off wheels in premium PFERD TOOLS quality up to 2,000 mm (80") diameter, tailor-made to meet the requirements of your special application. Please contact us for further information. Our experienced technical advisers will gladly assist you.

Scan the QR code to access the contact form.



Cut-off wheels for stationary applications

Highlights from the PFERD TOOLS range



Find additional in-depth information online

Scan the QR code to find out a wide range of tool and application knowledge relating to PFERD TOOLS' high-quality tools and their huge variety of materials.

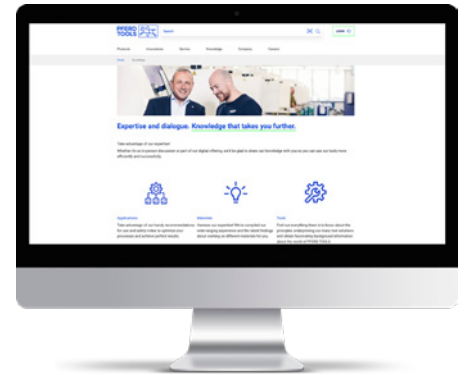

General information

Advantages of stationary cut-off grinding

- Universal cutting process for all steels and castings, non-ferrous metal alloys, special alloys such as nickel and titanium-based alloys, as well as materials on which sawing and flame cutting are difficult or impossible.
- No post-processing is required due to smooth cutting surfaces and blank cuts in cold cutting-off.
- Short cutting times regardless of the material quality.
- Significantly lower burr formation with hot cutting-off than with hot sawing.
- Lower noise levels than with hot sawing.
Example:
Hot cutting-off: 85 to 95 dBA
Hot sawing: 105 to 110 dBA
- Consistent cutting performance over the entire life of the cut-off wheel due to its continuous self-sharpening qualities.
- Enables cutting of already cooled rolled or forged parts in hot cut lines.

Applications

Cut-off grinding is one of the most powerful and cost-effective cutting processes and is used in the following areas:

- Rolling mills
- Foundries
- Mechanical engineering
- Steel construction
- Rail maintenance
- Forging plants and their finishing processes
- Laboratories

7

Safety notes

PFERD TOOLS is a founding member of oSa

Together with other renowned manufacturers, PFERD TOOLS voluntarily produces quality products conforming to the most exacting safety standards. Member companies of oSa (the Organization for the Safety of Abrasives) are committed to continuous product safety and quality monitoring. PFERD TOOLS products carry the oSa mark. Scan the QR code for further information.



Safety standard:

- PFERD TOOLS cut-off wheels conform to the highest safety requirements and are marked according to EN 12413 for grinding tools made of bonded abrasives.

Cut-off wheels for stationary applications

Safety notes

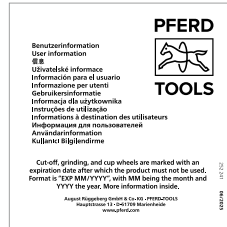

German Abrasives Association (VDS)

Please observe all relevant safety guidelines. Further information can be found at: www.pferd.com

User information

Please observe the user information provided with all products on the safe use of stationary cut-off wheels as well as the user information for the grinding machine used.

FEPA

The FEPA safety recommendations can be downloaded at www.pferd.com.

Proper clamping of cut-off wheels

The correct clamping of the cut-off wheel is a prerequisite for optimum performance and is essential to ensure user safety. The adjacent illustration shows the right way to do it:

- ① Machine spindle with high concentricity.
- ② Equally sized flanges.
- ③ Intermediate paper layers (blotters), if required for secure clamping and safe use.

Our recommendations:

- After every second wheel change, change the intermediate paper layers (blotters).
- As from a wheel diameter > 16 inches, always use intermediate paper layers (blotters).

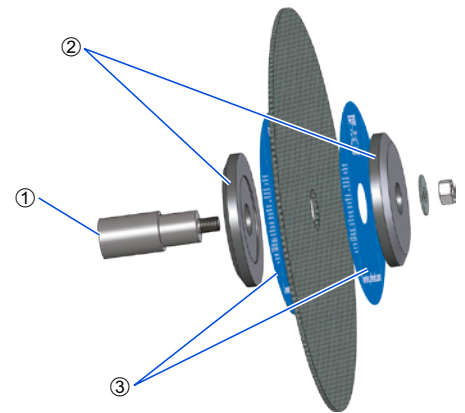

Safety notes

The safe use of PFERD TOOLS products depends largely on proper clamping systems. Both flanges between which a grinding tool is mounted must have the same outer diameter and same support area (according to EN 13218, ANSI B7.1).

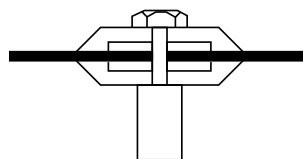

Correct

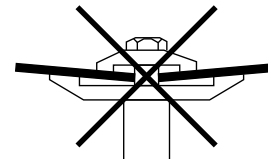

Incorrect



Cut-off wheels for stationary applications

Transport and storage



Transport and storage

To avoid damage to the cut-off wheels through improper transport or adverse environmental influences during storage, e.g. UV radiation, temperature or humidity, please observe the following advice:

- As much as possible, transport and store cut-off wheels in their original packaging and lying on a flat surface, e.g. on a shelf or vertically in racks.
- Avoid bending the wheels.
- Ensure that the cut-off wheels are stored in dry, frost-free rooms with consistent temperatures.
- Use supplies in the order of their arrival.

Storage advice for conical wheels (CT):

Conical cut-off wheels must be stacked with intermediate paper layers (blotters), so that the tapered area is supported and bending of the cut-off wheels is avoided. PFERD TOOLS supplies conical cut-off wheels with intermediate paper layers (blotters) included.

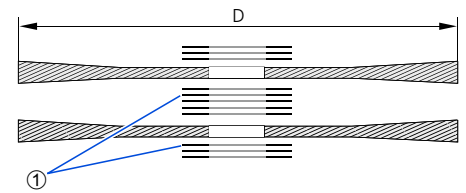
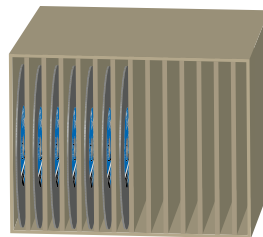
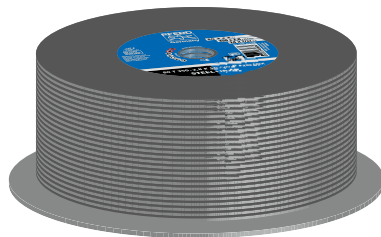

① Intermediate paper layers

Recommendation

18°C \rightarrow 22°C
Room temperature: 65-72°F

Relative humidity: 45-65%

No direct sunlight

Product lines and color coding



Universal Line PSF ★★☆☆

The introductory range Universal Line PSF features **quality products** designed for the **most common applications** and materials. Ideal for a wide range of end-users that require **strong performance**.



Performance Line SG ★★★☆

The broad Performance Line SG range offers a **high-performance product solutions for a diverse range of applications and materials**. Ideal for demanding industrial applications and achieving **optimal results with maximum cost-effectiveness**.



Special Line SGP ★★★★★

Special Line SGP products are meticulously crafted for **specific tasks and applications**, providing users with **nuanced advantages over conventional products**. Known for exceptional performance in the most demanding applications.

Cut-off wheels for stationary applications

Quick product selection guide

Product labels

① oSa – Organization for the Safety of Abrasives

As a founding member of oSa, PFERD TOOLS voluntarily manufactures quality tools conforming to the strictest safety standards. Member companies of oSa are committed to continuous product safety and quality monitoring.

② Safety information

Handling grinding tools is dangerous. Observe all safety rules and regulations.

③ Recommended power tool

The pictogram shows on which power tool the product can be used.

④ Material information

The bottom section of every label indicates the material or materials for which the product is suitable.

⑤ Information bar

Here you will find the product line and the dimensions.

⑥ EAN (European Article Number)

⑦ Hardness grade

The hardness denotes the strength with which the abrasive grit is held by the bond within the grinding wheel. The hardness is indicated with a letter:

K, H = very soft / L, N = soft /
O, P, Q = medium-hard / R, S = hard /
T = very hard

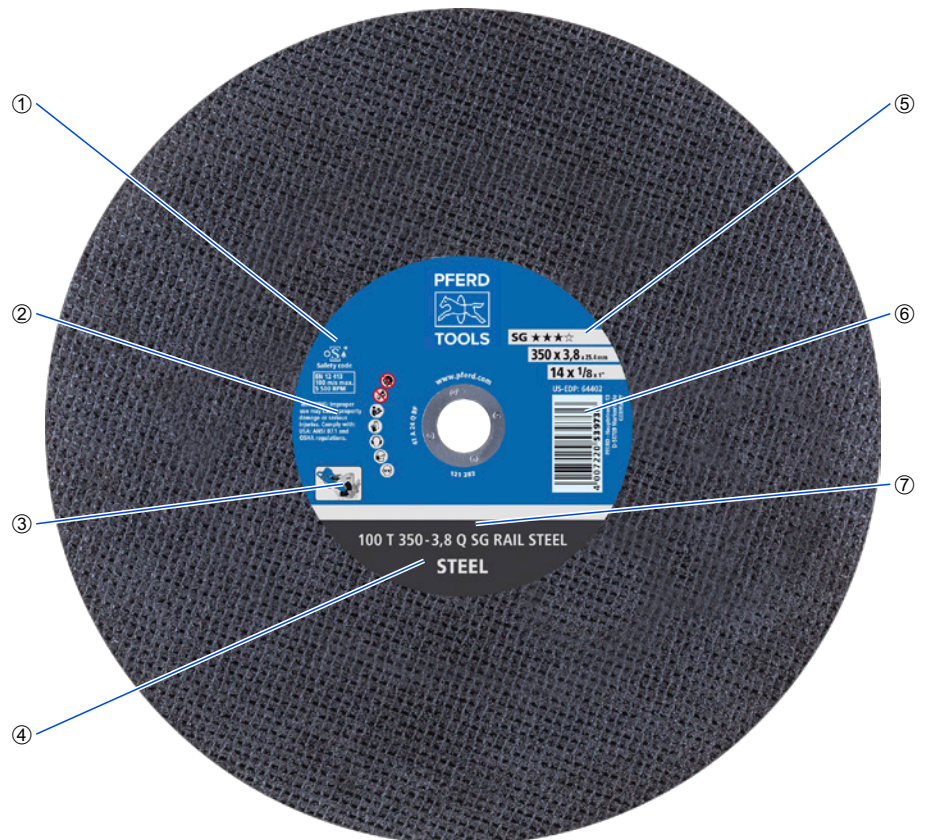

















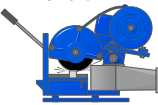

Cut-off wheels for stationary applications

Quick product selection guide

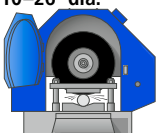
**PFERD
TOOLS**



Product group selection

Tool drive	Application	Product line	Steel (STEEL)			Stainless steel (INOX)	Cast material (CAST)
CHOPSAW dia. 300–400 mm 12–16" dia. < 3 KW 	Cutting of solid material, profiles and pipes	Universal Line PSF ★★★☆☆	 PSF CHOP STEEL Hardness K	 PSF CHOP STEELOX Hardness K	 PSF CHOP STEELOX Hardness K		
		Performance Line SG ★★★☆☆	 SG CHOP STEEL Hardness K	 SG CHOP STEELOX Hardness K	 SG STUD STEELOX Hardness K	 SG CHOP STEELOX Hardness K	
CHOPSAW HD dia. 300–400 mm 12–16" dia. 	Cutting of solid material, profiles and pipes	Performance Line SG ★★★☆☆	 SG CHOP HD STEEL Hardness L + O				
RAIL dia. 300–400 mm 12–16" dia. 	Cutting of rails	Universal Line PSF ★★★☆☆	 PSF RAIL STEEL Hardness Q				
		Performance Line SG ★★★☆☆	 SG RAIL STEEL Hardness Q				
HEAVY DUTY dia. 250–600 mm 10–26" dia. 	Cutting of solid material, profiles and pipes	Special Line SGP ★★★☆☆	 SGP HD STEEL Hardness N, Q + S	 ZIRKON SGP HD CAST + STEEL Hardness R		 ZIRKON SGP HD CAST + STEEL Hardness R	
Products made to order up to dia. 2,000 mm 10–80" dia. 	On request, we can produce stationary cut-off wheels in premium PFERD TOOLS quality up to a diameter of 2,000 mm (80"), tailor-made to meet the requirements of your special application. Please contact us for further information. Our experienced technical advisers will be pleased to assist you.						
 With middle reinforcement layer for aggressive cutting with minimized burr formation			 With two outer reinforcement layers for high lateral stability				

Cut-off wheels for stationary applications

Custom-made products



Dimensions and designs to meet customer requirements

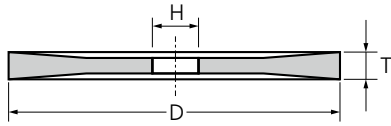

CT – Conical type

Excellent for use in the steel industry.

Advantages:

- Less lateral friction.
- Ideal for deep cuts and traverse cutting.

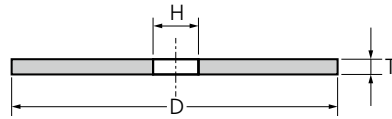

T – Flat type

Designed for use in steel and plant construction, in the steel industry and in foundries.

Advantages:

- Designed for universal use.

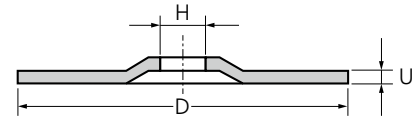

PT – Depressed-center type

Excellent designed for use in foundries.

Advantages:

- Clamping flange does not protrude beyond the cut-off wheel.
- Flush cutting of risers from castings is possible.
- In general, no post-processing required.

Outer dia. D [mm(inch)]	Centre hole diameter H [mm(inch)]
2,000 (80")	80/100/127 (5")/152.4 (6")/200/203.3 (8")/230/280
1,840 (73")	80/100/127 (5")/152.4 (6")/200/203.3 (8")/230/280
1,600 (63")	80/100/127 (5")/152.4 (6")/200/203.3 (8")/230/280
1,500 (60")	80/100/127 (5")/152.4 (6")/200/203.3 (8")/230/280
1,380 (55")	80/100/127 (5")/152.4 (6")/200/203.3 (8")/230/280
1,250 (50")	80/100/127 (5")/152.4 (6")/200/203.3 (8")/230/250/280
1,000 (40")	80/100/127 (5")/152.4 (6")/200/203.3 (8")/230
800 (32")	80/100/127 (5")/152.4 (6")/200/203.3 (8")/230

Outer dia. D [mm(inch)]	Centre hole diameter H [mm(inch)]
800 (32")	80/100/127 (5")/152.4 (6")/200/203.3 (8")/230
700 (28")	80/100/127 (5")/152.4 (6")/200/203.3 (8")/230
660 (26")	25.4 (1")/40/60/76.2 (3")/80/100
600 (24")	25.4 (1")/40/60/76.2 (3")/80/100
500 (20")	25.4 (1")/40/60/76.2 (3")/80/100
450 (18")	25.4 (1")/32 (1-1/4")/40/60/80
400 (16")	25.4 (1")/32 (1-1/4")/40/60/80
350 (14")	25.4 (1")/32 (1-1/4")/40
300 (12")	25.4 (1")/32 (1-1/4")/40
250 (10")	25.4 (1")/30/32 (1-1/4")

Outer dia. D [mm(inch)]	Centre hole diameter H [mm(inch)]
800 (32")	80/100
700 (28")	80/100
600 (24")	60/76.2 (3")/80/100
500 (20")	40/60/76.2 (3")/80/100
400 (16")	40/60/80

Other designs and center hole diameters are available on request. Please contact us for further information.



Cut-off wheels for stationary applications

Custom-made products



METALCORE cut-off wheel

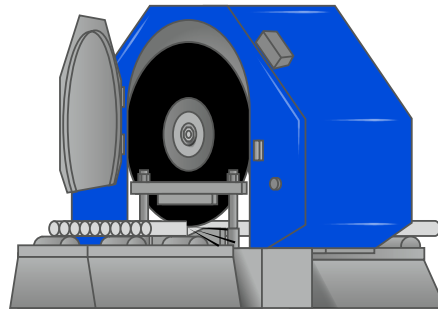

METALCORE type

The PFERD TOOLS developed steel-core cut-off wheel is characterized by its solid steel body constructed in layers which do not contain any abrasive material.

The product structure has the following advantages:

- Reduced cutting costs due to the use of smaller clamping flanges.
- Longer service life.
- Reduced cut-off wheel width for chop stroke cut due to increased lateral stability.
- No cost for the disposal of the old wheel.

Conventional type

For stationary cut-off grinding, resinoid-bonded, fibre-reinforced cut-off wheels are used, which are composed of four components: abrasive, bond, fabric layers/flange reinforcement and active grinding fillers.

Structure of cut-off wheels

- ① Steel core
- ② Flange reinforcement
- ③ Reinforcement layers
- ④ Bonded abrasives

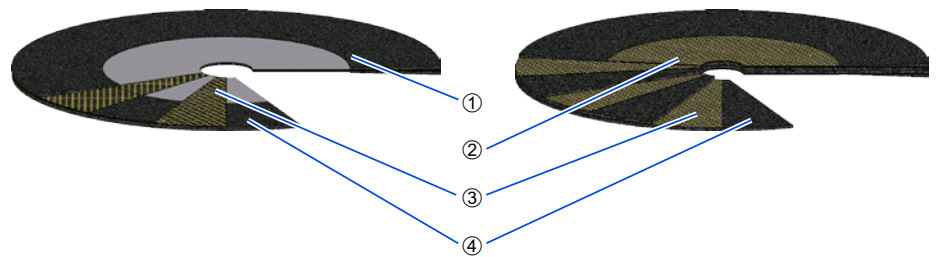

7



CHOPSAW cut-off wheels 12–16" dia.

Universal Line PSF ★★☆☆



PSF CHOP STEEL ★★☆☆

General purpose K hardness wheel for steel that has a middle reinforcement layer. Aggressive free cutting with minimal burr formation. Designed for cutting solid material, profiles and pipes. Compatible with: CHOPSAW up to 5 horsepower.

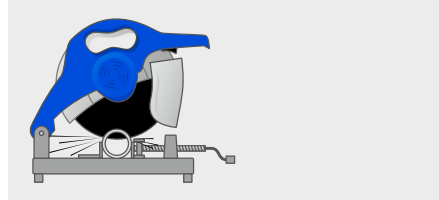

- Fast work due to high cutting performance.
- Minimal burr formation during cutting due to reduced lateral friction.

Special features:

- High economic efficiency due to long service life.

Maximum operating speed	D [Inch]	T [Inch]	H [Inch]	Hardness grade	Max. RPM	Abrasive		Item no.	EDP no.
Flat design T (type 41)									
80	12	7/64	1	K (very soft)	5,100	A	20	66323074	64491
	14	7/64	1	K (very soft)	4,400	A	10	66323574	64492
	16	1/8	1	K (very soft)	3,800	A	10	66324095	64493



PSF CHOP STEELOX ★★☆☆

K hardness wheel for steel and stainless steel (INOX), which cuts very easily and has a middle reinforcement layer. For aggressive cutting with minimal burr formation. Designed for cutting solid material, profiles and pipes. Compatible with: CHOPSAW up to 5 horsepower.

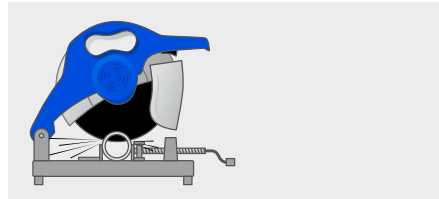

- Fast work progress due to high cutting performance.
- Minimal burr formation during cutting due to reduced lateral friction.

Special features:

- High economic efficiency due to long service life.

Maximum operating speed	D [Inch]	T [Inch]	H [Inch]	Hardness grade	Max. RPM	Abrasive		Item no.	EDP no.
Flat design T (type 41)									
80	12	7/64	1	K (very soft)	5,100	A	20	66323075	64497
	14	7/64	1	K (very soft)	4,400	A	10	66323575	64498
	16	1/8	1	K (very soft)	3,800	A	10	66324096	64499



CHOPSAW cut-off wheels 12–16" dia.

Performance Line SG ★★☆☆



SG CHOP STEEL ★★☆☆

General purpose K hardness wheel for steel that has a middle reinforcement layer. Aggressive free cutting with minimal burr formation. Designed for cutting solid material, profiles and pipes. Compatible with: CHOPSAW up to 5 horsepower.

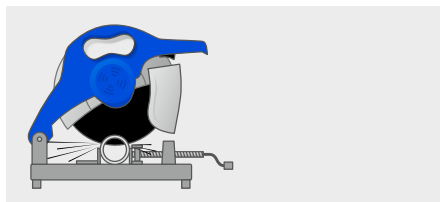

- Reduced labor time due to very high cutting performance.
- Minimal burr formation during cutting due to reduced lateral friction.

Special features:

- Maximum economic efficiency due to very long service life.

Maximum operating speed	D [Inch]	T [Inch]	H [Inch]	Hardness grade	Max. RPM	Abrasive		Item no.	EDP no.
Flat design T (type 41)									
80	12	7/64	1	K (very soft)	5,100	A	20	66323070	64501
	14	7/64	1	K (very soft)	4,400	A	10	66323570	64502
	16	1/8	1	K (very soft)	3,800	A	10	66324093	64503



SG CHOP STEELOX ★★☆☆

K hardness wheel for steel and stainless steel (INOX), which cuts very easily and has a middle reinforcement layer. For aggressive cutting with minimal burr formation. Designed for cutting solid material, profiles and pipes. Compatible with: CHOPSAW up to 5 horsepower.

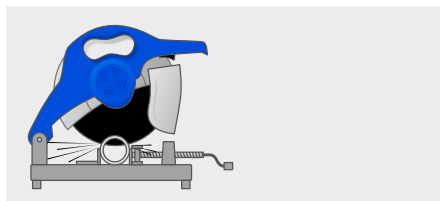

- Reduced labor time due to very high cutting performance.
- Minimal burr formation during cutting due to reduced lateral friction.

Special features:

- Maximum economic efficiency due to very long service life.

Maximum operating speed	D [Inch]	T [Inch]	H [Inch]	Hardness grade	Max. RPM	Abrasive		Item no.	EDP no.
Flat design T (type 41)									
80	12	7/64	1	K (very soft)	5,100	A	20	66323052	64510
	14	7/64	1	K (very soft)	4,400	A	10	66323572	64508
	16	7/64	1	K (very soft)	3,800	A	10	66324091	64509

CHOPSAW cut-off wheels 12–16" dia.

Performance Line SG ★★☆☆

**PFERD
TOOLS**



SG STUD STEEL ★★☆☆

K hardness wheel with good cutting characteristics for steel; has two outer reinforcement layers. For cutting work that requires high stability. Designed for cutting solid material, profiles and pipes. Compatible with: CHOPSAW HD.

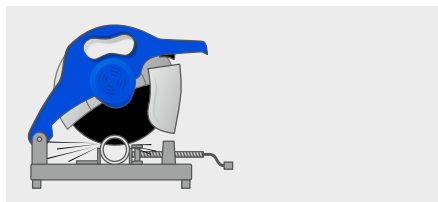

- Maximum economic efficiency due to very long service life.
- Designed for cutting bundled or stacked drywall profiles and other thin steel profiles.

Special features:

- High lateral stability due to outer reinforcement layers.

Maximum operating speed	D [Inch]	T [Inch]	H [Inch]	Hardness grade	Max. RPM	Abrasive		Item no.	EDP no.
Flat design T (type 41)									
80	12	7/64	1	K (very soft)	5,100	A	20	69620714	64504
	14	7/64	1	K (very soft)	4,400	A	10	69620715	64505

CHOPSAW HD cut-off wheels 12–16" dia.

Performance Line SG ★★☆☆



SG CHOP HD STEEL ★★☆☆

Heavy duty L hardness wheel for steel that has two outer reinforcement layers. For cutting work that requires high stability. Designed for cutting solid material, profiles and pipes. Compatible with: CHOPSAW HD.

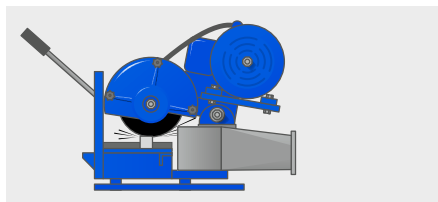

- Maximum economic efficiency due to very long service life.
- For demanding cutting work.

Special features:

- High lateral stability due to outer reinforcement layers.

Maximum operating speed	D [Inch]	T [Inch]	H [Inch]	Hardness grade	Max. RPM	Abrasive		Item no.	EDP no.
Flat design T (type 41)									
80	12	7/64	1	L (soft)	5,100	A	20	66323080	64530
	14	7/64	1	L (soft)	4,400	A	10	66323580	64531
	16	1/8	1	L (soft)	3,800	A	10	66324080	64532



Rail cut-off wheels dia. 14" – 16"

Universal Line PSF ★★☆☆



PSF RAIL STEEL ★★☆☆

Q hardness wheel for fast and cost-effective rail cutting. Compatible with: RAIL cutting machine.

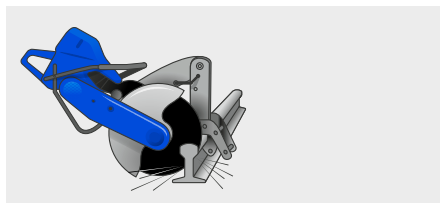

- High economic efficiency due to optimal durability.

Special features:

- Fast working progress due to aggressive abrasive.
- Safe cutting work due to the highest possible cutting quality.

Maximum operating speed	D [Inch]	T [Inch]	H [Inch]	Hardness grade	Max. RPM	Abrasive		Item no.	EDP no.
Flat design T (type 41)									
100	14	5/32	1	Q (medium-hard)	5,500	A	10	73001230	64405

Performance Line SG ★★☆☆



SG RAIL STEEL ★★☆☆

Q hardness wheel for fast and cost-effective rail cutting. Compatible with: RAIL cutting machine.

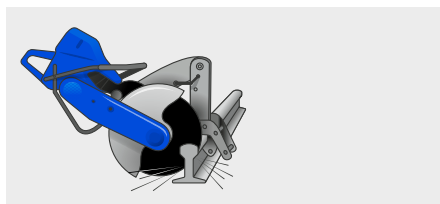

- High economic efficiency due to optimal durability.

Special features:

- Reduced labor time due to aggressive abrasive.
- Safe cutting work due to the highest possible cutting quality.

Maximum operating speed	D [Inch]	T [Inch]	H [Inch]	Hardness grade	Max. RPM	Abrasive		Item no.	EDP no.
Flat design T (type 41)									
100	12	1/8	20 mm	Q (medium-hard)	6,400	A	20	69901520	64395
			1	Q (medium-hard)	6,400	A	20	66323163	64401
	14	1/8	20 mm	Q (medium-hard)	5,500	A	10	69901529	64396
			1	Q (medium-hard)	5,500	A	10	66323663	64402
	16	1/8	20 mm	Q (medium-hard)	4,800	A	10	69901530	64397
			1	Q (medium-hard)	4,800	A	10	66324163	64403



HEAVY DUTY cut-off wheels 10–26" dia.

Special Line SGP ★★★★★



SGP HD STEEL ★★★★★

For the most demanding cutting work on steel. Ideal for finishing work and cutting solid material, profiles, pipes and large cross-sections. Compatible tool drives: HEAVY DUTY cutting machine.

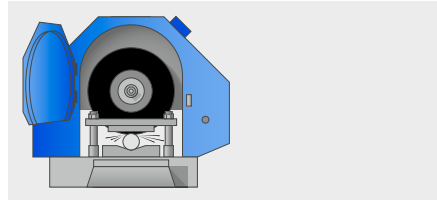

- Fast work due to excellent cutting characteristics.

Special features:

- Ultimate economic efficiency due to optimum durability.

Maximum operating speed	D [Inch]	T [Inch]	H [Inch]	Hardness grade	Max. RPM	Abrasive		Item no.	EDP no.
Flat design T (type 41)									
80	10	3/32	5/8	S (hard)	6,100	A	20	69620727	66113
			1	S (hard)	6,100	A	20	69620726	66114
	12	1/8	1	Q (medium-hard)	5,100	A	20	66323025	66115
	14	1/8	1	Q (medium-hard)	4,400	A	10	66323525	66116
	16	1/8	1	Q (medium-hard)	3,800	A	10	69620558	66117
	20	3/16	1	N (soft)	3,800	A	5	69721000	66005
				Q (medium-hard)	3,100	A	5	69720781	66123
	26	1/4	1	N (soft)	2,300	A	5	69721003	66132
100	10	1/8	5/8	Q (medium-hard)	7,600	A	20	69620446	66009
	12	1/8	1	Q (medium-hard)	6,400	A	20	66323125	66011
	14	1/8	1	Q (medium-hard)	5,500	A	10	66323625	66012
	16	3/16	1	S (hard)	4,800	A	10	69620325	66013
	18	3/16	1	N (soft)	4,200	A	5	69620495	66016
	20	1/4	1	N (soft)	3,800	A	5	69720131	66019
	24	1/4	1	N (soft)	3,200	A	5	69720855	66022



HEAVY DUTY cut-off wheels 10–26" dia.

Special Line SGP ★★☆☆



ZIRKON SGP HD CAST+STEEL ★★☆☆

For the most demanding cutting work on cast iron and steel. Suitable for cutting risers, sprues, solid material, profiles, pipes and large cross-sections. Developed for use in foundries. Compatible with: HEAVY DUTY cutting machine.

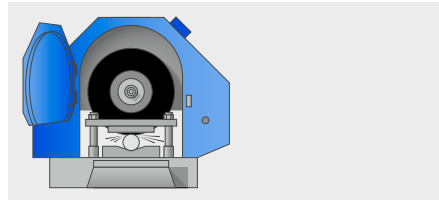

- Fast work due to excellent cutting characteristics.
- Products made to order available on request.

Special features:

- Ultimate economic efficiency due to optimum durability.

Maximum operating speed	D [Inch]	T [Inch]	H [Inch]	Hardness grade	Max. RPM	Abrasive		Item no.	EDP no.
Flat design T (type 41)									
100	20	3/16	1	R (hard)	3,800	Z/A	5	69720830	66045
	24	1/4	2-3/8	R (hard)	3,200	Z/A	5	66397196	66050



Reducing rings for stationary cut-off wheels

Reducing rings for stationary cut-off wheels

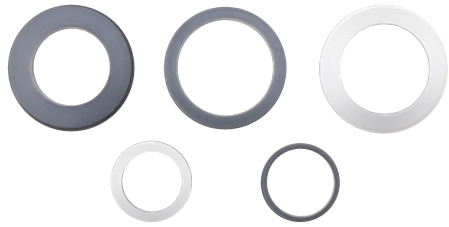

Reducing rings for stationary cut-off wheels

PFERD TOOLS bench grinder bushings provide a safe method of reducing the wheel arbor to accommodate various spindle sizes. The bushing should be flush on both sides of the wheel, and should not interfere with the flanges.

Special features:

- Flexible adjustment to the prerequisites of the drive system.
- Stop collar, to prevent the ring from pushing through the center hole of the cut-off wheel.

External diameter [Inch]	Inner diameter [Inch]	Width [Inch]		Item no.	EDP no.
1-1/2	1-3/16	3/16	1	*69900007	69001
2-3/8	1	1/4	1	79168621	69020
	1-1/4	1/4	1	69901521	69021
	1-1/2	1/4	1	69901522	69022
	1-3/4	1/4	1	69901523	69023
1-1/2	1-1/4	3/16	1	69900006	69007
1-1/8	1	1/8	1	69900015	69008
1	7/8	1/8	1	69901392	69003
	20	1/8	1	69901393	69004
	5/8	1/8	1	69901394	69005
	5/8	1/8	1	69901394	69005
7/8	5/8	5/64	1	69900021	69006

